

Standard Construction and Materials

FRAME: .081" thick (nominal) extruded aluminum, 6063-T52/T6 alloy.

BLADE: .081" thick (nominal) extruded aluminum, 6063-T52/T6 alloy.
Blade approximately 2¼" on centers.

LOUVER FACE: Head and blades are contained within jambs. Sill contains jambs.

SCREEN: (When indicated, in a removable frame.)

½" flattened aluminum (.051" thick),

-or- ½" sq. mesh, intermediate double-crimped aluminum wire, .063" dia.,

-or- 18/16 mesh, .011" dia. aluminum wire, insect screen.

FINISH: Mill

Options

Finish - Baked Enamel, Kynar, Anodize

Notes

1. Nominal deductions will be made to opening sizes given.
2. Louvers larger than the maximum factory assembled size will require field assembly of smaller louver sections.
3. Approximate shipping weight is 9.0 lbs./sq.ft.

Louver Sizes

Min Panel	Max Single Panel
12"W x 12"H	30 sq.ft.

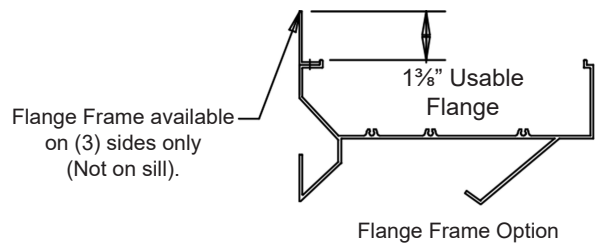
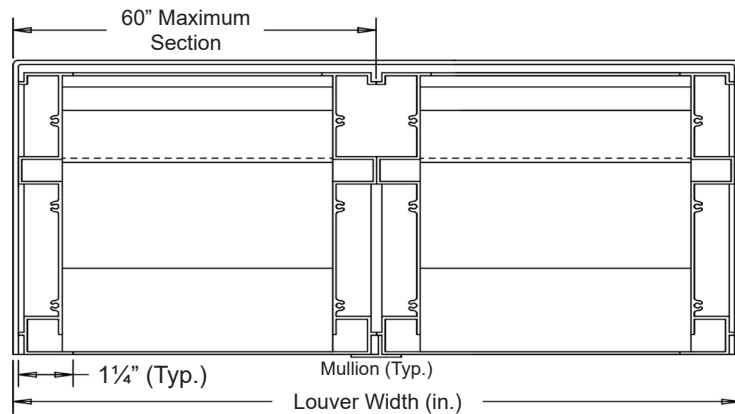
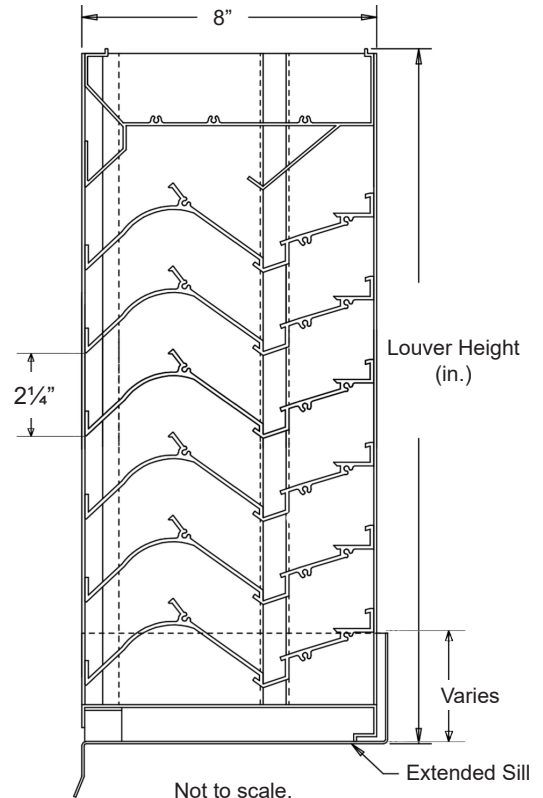

										
Item #	Qty	Width	Height	Width	Height	Mullion	Type	Location		
		Opening Size		Louver Size			Screens			
Arch. / Eng.:						EDR:	ECN:		Job:	
Contractor:										
Project:						Date:	DWN:	DWG:		

In the interest of product development, Cesco Products reserves the right to make changes without notice.

Performance Data

Pressure Drop: Less than .50 in. w.g. at 1000 fpm (intake)

Free Area: 9.01 sq.ft. = 56% for 48"W x 48"H sample tested in accordance with AMCA Standard 500-L.

Class "A" Rating with 99% efficiency at 3 in. rain fall at intake velocity of 888 fpm (8,000 cfm) at wind speed of 29 mph. Testing based on 48" x 48" based on AMCA Standard 500-L.

Ratings do not include effects of a screen.

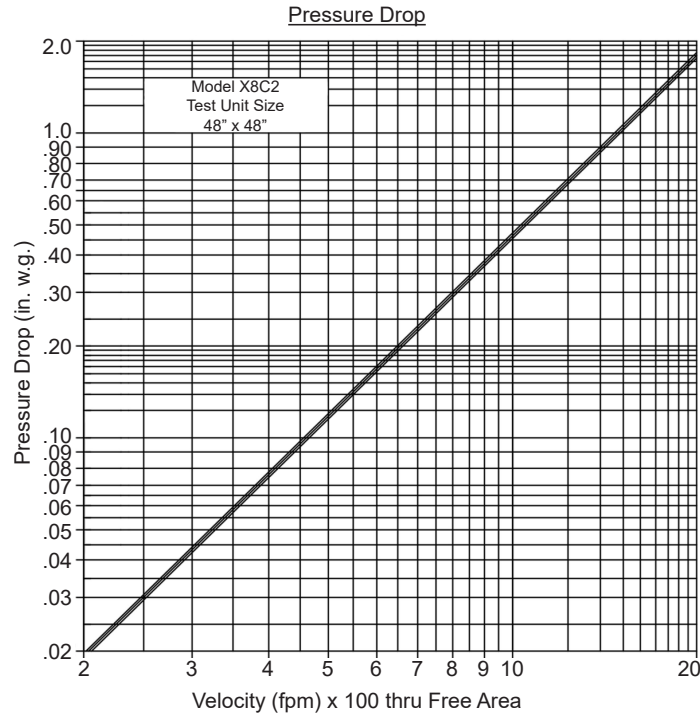

Intake air converted to standard air density.
Tested to AMCA Standard 500-L, Figure 5.5.

Wind Driven Rain Test based on 39"W x 39"H Core Area

Class	Effectiveness (%)	Maximum Allowed Penetration of Simulated Rain (gal/h/ft ²)	Free Area Velocity	CFM (48" x 48")
A	99	3" rainfall and 29 mph wind velocity	888 FPM	8000 CFM

Free Area (sq.ft.)

		Width (in.)								
		12"	18"	24"	30"	36"	42"	48"	54"	60"
Height (in.)	12"	.30	.49	.68	.87	1.06	1.25	1.44	1.63	1.82
	24"	.83	1.36	1.89	2.42	2.95	3.48	4.01	4.54	5.07
	36"	1.37	2.24	3.12	3.99	4.86	5.74	6.61	7.49	8.36
	48"	1.86	3.05	4.24	5.43	6.62	7.82	9.01	10.20	11.39
	60"	2.39	3.92	5.45	6.98	8.52	10.05	11.58	13.11	14.64
	72"	2.93	4.80	6.68	8.55	10.43	12.30	14.18	16.05	17.92
	84"	3.42	5.62	7.81	10.00	12.19	14.38	16.57	18.76	20.95
	96"	3.96	6.49	9.02	11.55	14.08	16.61	19.14	21.67	24.20